

## Conditioned Taste Aversion Induced by Exposure to High-Strength Static Magnetic Fields

THOMAS A. HOUPT AND JAMES C. SMITH

In the 112 years since the original discovery of X-rays and Roentgen's famous radiogram of the bones of a hand, *in vivo* imaging of the human body has progressed from the novel to the commonplace. Radiation-based imaging, such as X-rays, computer-assisted tomography, and positron-emission tomography, and more recently magnetic resonance imaging (MRI) are now ubiquitous technologies in many countries. Although there were reports from the very beginning that X-rays were sensible (implying interaction with sensory receptors), X-radiation was initially considered benign and noninvasive. Subsequently, it became clear that X-radiation and other forms of high-energy radiation such as gamma radiation were capable of ionizing atoms within the body, with destructive effect. Similarly, the high-strength magnetic fields used in MRI machines are generally considered benign without significant effects on biological tissue. There are reports, however, of vertigo and nausea in subjects exposed to 4 tesla (T) or higher fields (Kangarlu et al., 1999; Schenck et al., 1992). Furthermore, we found significant interactions of high magnetic fields with the vestibular system in rodents. Although high magnetic fields contain far less energy than clinical X-radiation, the apparent ability of magnetic fields to be detected by humans and rodents implies an action of magnetic fields on sensitive tissues.

In this review we summarize the application of conditioned taste aversion (CTA) learning to

determine the sensitivity of animals to high magnetic fields, and to determine the sites of action for their different effects. We also summarize the earlier work of JCS and colleagues on CTA and ionizing radiation, which has served as a model for our analysis of magnetic field effects. In both cases with either radiation or magnetic field exposure used as the unconditioned stimuli (USs), CTA revealed an effect on animals in the absence of other overt behavioral symptoms. CTA experiments also demonstrated that the site of action of ionizing radiation to induce CTA is the histamine-containing mast cells of the abdomen, while magnetic fields interact with the peripheral vestibular apparatus of the inner ear.

### IONIZING RADIATION

I (JCS) became interested in taste aversion learning in the late 1950s. My professor, W. N. Kellogg, asked me to review the literature on behavioral effects from exposure to ionizing radiation. W. Roentgen, who has been given credit for the discovery of X-rays in 1895, thought at that time that these rays were not perceptible (Roentgen, 1895). In his third paper in 1897, however, he withdrew this claim and described experiments in which he "saw" the beam as a glow in his eye (Roentgen, 1897). The general belief was that these rays were harmless and it took quite a few years before the

deleterious effects on living tissue were fully realized. By the middle of the twentieth century, reports were beginning to appear that exposure to X- and gamma-rays had behavioral effects in addition to physiological effects. The seminal paper was published in *Science* in 1955 by Garcia, Kimeldorf, and Koelling (1955). They showed that one pairing of saccharin-flavored water with an exposure to gamma-rays resulted in a subsequent aversion to the sweet solution. CTA had been described earlier by Barnett (i.e., bait-shyness; Barnett, 1963) and others, but most of us date the formal description of CTA from that 1955 paper. I had the good fortune to spend two summers in 1962–1963 at the Naval Radiological Defense Laboratory working with Donald J. Kimeldorf. With support from the Atomic Energy Commission, and later, the United States Air Force and the National Cancer Institute, we initiated at FSU a long series of studies using X- and gamma-rays as both an US and a conditioned stimulus (CS), which are reviewed in greater detail elsewhere (Smith, 1971).

CTA as a result of exposure to ionizing radiation provided an interesting challenge since little was known about the unconditioned response to radiation exposure. In the typical design we prepared for the conditioning trial by training the rat to drink most of its daily supply of water during a brief 10-min exposure. This insured that the “thirsty” rat would drink a novel 0.1% saccharin solution on conditioning day. The 10-min saccharin exposure was followed by, for example, a single 100 roentgen (R) whole-body exposure of X- or gamma-rays. Control groups were treated in a like manner, but were given either sham exposures to the ionizing radiation or received water (but not saccharin) paired with irradiation on conditioning day. On the first postconditioning day we would initiate a two-bottle preference test between the saccharin solution and water. Saccharin preference was calculated as the ratio of saccharin intake to total fluid intake. The radiation groups showed a profound aversion to the saccharin and the control groups readily showed a strong preference for the sweet solution. Often we continued these daily preference tests until the aversion was extinguished to provide a measure of CTA strength (Spector, Smith, & Hollander, 1981).

Our initial studies focused on the parameters of radiation exposure such as threshold doses, wave length, and rate of irradiation (Smith, Morris, & Hendricks, 1964; Spector et al., 1986).

We showed that novel tastes produced stronger aversions than familiar tastes. We also explored the temporal relations between the initiation of the period of tasting and the onset of the radiation exposure (Smith & Roll, 1967), being among the first to demonstrate that CTA learning could tolerate very long time periods between the CS (taste) and the US (irradiation; Carroll & Smith, 1974; Morris & Smith, 1964; Smith & Schaeffer, 1967; Smith, Taylor, Morris, & Hendricks, 1965; Spector et al., 1983).

In her master’s thesis, Marilyn Carroll showed that the aversive response to gamma-ray exposure was not immediate, but peaked about 90 min following the onset of the exposure period (Carroll & Smith, 1974). She did this by exposing a water-deprived rat to a 100-R dose and then immediately placing the rat in a cage equipped with a lickometer, allowing the rat to freely consume saccharin-flavored water. She found that in about 90 min the irradiated rats stopped drinking. Sham-exposed rats, however, kept drinking long after the gamma-ray-exposed rats had stopped. These results raised the question, “was 90 min the period of time that it took the rat to feel the most discomfort from the irradiation, or did it take 90 min to form a conditioned taste aversion?” She answered this by imposing different time delays between the irradiation and the initiation of the saccharin drinking period. It became clear that she was measuring the “discomfort,” since rats that were given a 90-min delay between irradiation and onset of the drinking period failed to drink the saccharin-flavored water at the outset.

It was known that following a 100-R exposure to X-rays there was a build up of histamine in the blood of a rat that peaked 90 min following the exposure (Levy, Carroll, Smith, & Hofer, 1974). There was also evidence that the unconditioned response to a radiation exposure was mediated in the blood (Garcia, Ervin, & Koelling, 1967; Hunt, Carroll, & Kimeldorf, 1965). Using a parabiotic rat procedure in which a pair of male rats were sutured together through the skin, Hunt et al. (1965) showed that if one member of the pair drank saccharin-flavored water and the other member was irradiated, the nonexposed member developed a taste aversion to the saccharin. Furthermore, Garcia et al. demonstrated that plasma from an irradiated rat injected into a thirsty naïve rat, after he drank saccharin-flavored water, developed a taste aversion to the saccharin (Garcia et al., 1967). Our hypothesis was

that the “toxic” substance in the blood was histamine. We treated rats with an antihistamine, chlorpheniramine, and found that it blocked acquisition of a CTA in an irradiated rat (Levy et al., 1974). Conversely, injections of histamine into naïve rats paired with saccharin-flavored water induced a CTA to the saccharin solution. Combined with evidence that the abdomen was the most sensitive site for radiation-induced CTA (see following section), we concluded that the unconditioned response to the irradiation was the result of tissue damage that resulted in the massive production of histamine, most likely from mast cells in the intestine.

### CLINICAL IMPLICATIONS OF RADIATION-INDUCED CTA

In the 1970s the National Cancer Institute put out a request for proposals to study the possible role of taste aversion learning as a contributing factor in the dietary problems experienced by cancer patients undergoing radiation and chemotherapy. The literature on CTA induced by ionizing radiation in rodents typically used procedures that did not match those used in therapy with human patients, however. We focused on three of the obvious differences:

1. Most of the rat studies utilized novel tastes as the CS, whereas the cancer patient would not necessarily be eating novel foods.
2. Most of the rat studies induced CTA in only one trial, whereas the human patient is often given the daily radiation exposure over a several week period.
3. Most of the rat studies involved whole-body exposure, whereas the human patient would typically receive only partial body exposures.

We developed a more suitable rat model for the conditions of human exposure by conditioning rats with familiar taste substances, applying multiple CS-US pairings, and limiting exposure to specific body regions (head, thorax, and abdomen). Rats were individually restrained in Plexiglas tubes. Laminar gamma-rays from a cobalt-60 source were presented through a 2.5-cm slit between two lead plates in order to expose specific parts of the body. We found that we could induce a significant CTA even with very low radiation doses by administering multiple trials. Furthermore, the

abdominal area was found to be the most sensitive body area (Smith, Hollander, & Spector, 1981). We then spent 3 years in the local hospital demonstrating learned taste aversion in radiotherapy patients (Smith & Blumsack, 1981; Smith, Blumsack, & Bilek, 1985; Smith et al., 1984). Similar studies by Ilene Bernstein also found that chemotherapy could induce CTA in cancer patients (Bernstein, 1978; Bernstein, Webster, & Bernstein, 1982).

If learned taste aversions were to play an important part in human cancer patients as a result of conditioning to radiation or chemotherapy, we needed to quantify the strength of the aversions and how long they lasted. Therefore, in our rat model, we began to add the number of days before extinction of the aversion as a measure of its strength (Spector et al., 1981). This became a standard test for all of our subsequent studies. One thing of interest was the large variation among rats in the time to extinction. Following an aversion conditioned by a 100-R radiation exposure, we found some rats extinguishing in 2 days and others showing no signs of extinction in several weeks (Spector et al., 1981). Presumably, similar variation in sensitivity exists among human patients as well.

### RADIATION AS A CS

There was evidence as far back as 1897 that ionizing radiation could be perceived through the retina if the subject was in a dark-adapted state (Roentgen, 1897). This led us to a series of experiments using X-rays as a CS, that is, to determine if our animals (rats, pigeons, and rhesus monkeys) could immediately detect the onset of the X- or gamma-ray beam, as opposed to showing the delayed toxic effects of irradiation. Using a conditioned suppression technique, we could measure the threshold for detection of ionizing radiation (Dinc & Smith, 1966; Smith, 1970; Taylor, Smith, Wall, & Chaddock, 1968). The immediate detection of ionizing radiation depended on the rate of the radiation (MR/s) and on head exposure. This was in sharp contrast to irradiation in the CTA experiments, in which the rate of the radiation dose was not important and exposure of the head alone was not an effective US at the lower doses. Subsequent experiments revealed that these animal subjects could immediately “smell” the radiation (i.e., due to the formation of ozone and/or oxides of nitrogen within the olfactory epithelium) and

they could “see” the radiation if in a truly dark-adapted state (i.e., due to direct effects on retinal photoreceptors). These forms of detection could be abolished by ablation of the olfactory bulb or optic enucleation, respectively.

## HIGH MAGNETIC FIELDS

In 1992, the U.S. National High Magnetic Field Laboratory (NHMFL) was moved from MIT to The Florida State University. At the strong encouragement of my late colleague, Bruce Masterton, we began to make preliminary observations regarding the rat’s sensitivity to very high-strength magnets, both in terms of the use of magnets to condition a taste aversion and the immediate detection of the onset of a magnetic field. In the summer of 1994, with the assistance of a NSF high school summer fellow, Ben Kalevitch, we demonstrated that a 9.4-T magnet exposure for 30 min was sufficient to condition a taste aversion that lasted about 2 weeks. Our preliminary studies indicated that the rat needed to be in the core of the magnet for the 30-min period and that passing through the gradient of the magnet for five sweeps was not sufficient to condition the aversion to saccharin-flavored water. In 1996, two neuroscience graduate students, Chris Nolte and David Pittman, quantified the magnet-induced taste aversion and published the first paper on this phenomenon (Nolte, Pittman, Kalevitch, Henderson, & Smith, 1998). Further research on magnet-induced taste aversion lay dormant until the arrival of TAH to The Florida State University in 1998. With the support of a program grant from the University and subsequent funding from the National Institute on Deafness and Other Communication Disorders (NIDCD), we began a series of studies that have continued to this day. Results of these experiments are summarized in the remainder of this chapter.

## MAGNETIC FIELDS AND MRI

Advances in MRI are driving the development of more powerful and higher-resolution MRI machines. While MRI machines with static magnetic fields of 1–3 T and resolutions of 2 mm<sup>3</sup> are standard in clinical use, higher resolution requires stronger magnetic fields: 4–8-T MRI machines are becoming available to achieve submillimeter

resolutions. Little is known about the sensory or physiological effects of static magnetic fields of high strength on mammals. (Although there is evidence that lower vertebrates can detect small gradients in weak, earth-strength magnetic fields [~50  $\mu$ T; Gould, 1998], and the biological effects of oscillatory magnetic fields are well established, Berardelli, 1991, our research is limited to the effects of high-strength, static magnetic fields of 2 T and above.)

MRI signals are generated with a static magnetic field on which radiofrequency (RF) pulses are applied. The RF pulse aligns the spins of protons in the biological sample, and the aligned spins induce a signal voltage in a receiver coil; the strength of this signal and its decay time under different RF pulse protocols allows the differential imaging of tissue components within the samples. The MR signal strength (and hence spatial resolution) is linearly dependent on field strength (Narasimhan & Jacobs, 1996). Thus, there is almost a hundred-fold increase in spatial resolution when the field strength is increased from 0.2 to 12 T. The theoretical limit is 0.5–2  $\mu$ m resolution (Narasimhan & Jacobs, 1996).

There have been reports of sensory and visceral disturbances in humans exposed to high magnetic fields. Some effects are transient and purely sensory, such as the phenomenon of magnetophosphenes: the perception of flashing light specks long known to be induced by magnetic fields by direct stimulation of retinal cells (Lövsund, Öberg, Nilsson, & Reuter, 1980). More significant are the reports of vertigo and nausea by workers around large magnets. These self-reports were quantified in the safety study of an early 4-T MRI machine (Schenck et al., 1992). Eleven male volunteers each received >100 h of cumulative exposure to 4 T in 90 sessions. Subjects responded to questionnaires on 11 sensory effects experienced during exposure, ranging from vertigo to muscle spasms. Only three effects occurred at a statistically significant level: vertigo, nausea, and metallic taste. Subjects also reported that head movements or rapid advances of the body into the magnetic field increased the sensation of nausea. There has also been a report of vertigo induced within an 8.4-T MRI machine used for human imaging (Kangarlu et al., 1999). The threshold for these side-effects may be close to 4 T, since exposure to lower magnetic fields such as 0.5 T (Winther, Rasmussen, Tvete, Halvorsen, & Haugsdal, 1999) or 1.5 T (Schenck et al., 1992) do not produce them.

Little work has been done in animal models on the effects of high-strength static magnetic fields

or MRI protocols. Ossenkopp and colleagues found no acute effects of a standard MRI protocol at 0.15 T on open-field behavior, passive avoidance learning, or spatial memory tasks in rats (Innis, Ossenkopp, Prato, & Sestini, 1986; Ossenkopp, Innis, Prato, & Sestini, 1986). No long-term effect on organ pathology and blood chemistry was found 13–22 months after exposure (Teskey, Ossenkopp, Prato, & Sestini, 1987), although the same group has reported an attenuation of morphine-induced analgesia in mice after MRI exposure at 0.15 T (Ossenkopp et al., 1985). Another group has reported that rats do not form a CTA after exposure to a 1.89-T field (Messmer, Porter, Fatouros, Prasad, & Weisberg, 1987). These experiments, however, were carried out using MRI machines that had weaker fields than are used today in most standard clinical MRI machines (e.g., 3 T) and experimental MRI machines (e.g., 8–11 T).

We have, therefore, been using CTA acquisition and other measures in rodents as an animal model of the behavioral and neural effects of high-strength magnetic fields. We found in rats and mice that exposure to 7-T or greater magnetic fields can induce locomotor circling, CTA, and c-Fos in visceral and vestibular nuclei of the brainstem (Haupt et al., 2005; Haupt, Pittman, Barranco, Brooks, & Smith, 2003; Nolte et al., 1998; Snyder, Jahng, Smith, & Haupt, 2000). Because rotation and motion sickness can induce CTAs (Arwas, Rolnick, & Lubow, 1989; Braun & McIntosh, 1973; Fox, Corcoran, & Brizee, 1990; Green & Rachlin, 1973; Hutchison, 1973) and stimulate similar c-Fos patterns (Kaufman, 1996; Kaufman, Anderson, & Beitz, 1991, 1992, 1993; Marshburn, Kaufman, Purcell, & Perachio, 1997), these results suggest that the rats may be experiencing a vestibular disturbance during magnetic field exposure comparable to the self-reports of humans.

#### SUPERCONDUCTING AND RESISTIVE MAGNETS

We employed two types of magnets at the NHMFL, superconducting nuclear magnetic resonance (NMR) magnets and a resistive magnet (see Figure 20.1). Both superconducting and resistive magnets are electromagnets. The advantages of the superconducting NMR machines are that they operate on the same principle as MRI machines, they produce extremely homogeneous fields, and

they are available at the NHMFL in a variety of field strengths (from 7 to 20 T). Because they are superconducting, the NMR magnets remain energized for months while drawing little outside current; however, it is very inconvenient to turn the magnetic field off and on again. Thus, we employed a “sham-magnet” for the 0-T controls (e.g., a PVC tube outside the magnetic field); this sham-magnet, of course, lacks many of the potential nonmagnetic characteristics of the NMR machine such as odor, sounds, and so on. Furthermore, the superconducting magnets are designed to be energized only to a set field strength, so that different strengths of magnetic field can only be applied by exposing animals within different superconducting magnets in different physical locations.

In resistive magnets, electric current circles the bore through regular copper wiring (which has some resistance), and not through superconductors (without resistance) as in the NMR magnets. To confirm our observations in the NMR magnets, we employed a resistive magnet at the NHMFL with a vertical bore of 189-mm diameter that can produce fields between 0 T and 20 T (Gao, Bird, Bole, Eyssa, & Schneider-Muntau, 1996). Because the magnetic field generated in a resistive magnet is proportional to the current, the field intensity can be varied by applying up to 40 kA at 500 V (20 MW) through the copper coils. The field strength falls off rapidly with distance, so that when the field is 20 T in the center of the magnet, the field is near 0 T at 2-m distance from the center. The polarity of the field can easily be reversed by reversing the current. The magnetic field also disappears when the current is stopped, so that controls can be run at 0 T within the same magnet. The major limitations on resistive magnets are the availability of electrical power (up to 20 MW for hours at a time) and the capacity to dissipate heat from the copper wiring during operation. While superconducting NMR and MRI magnets are fairly common, large resistive magnets are rare due to their size and cost of operation.

#### MAGNETIC FIELDS AS THE US FOR CTA LEARNING

Our protocol for determining the behavioral effects of high magnetic fields is very similar to the conditioning protocol described above for radiation treatment. Rats are housed in an animal facility

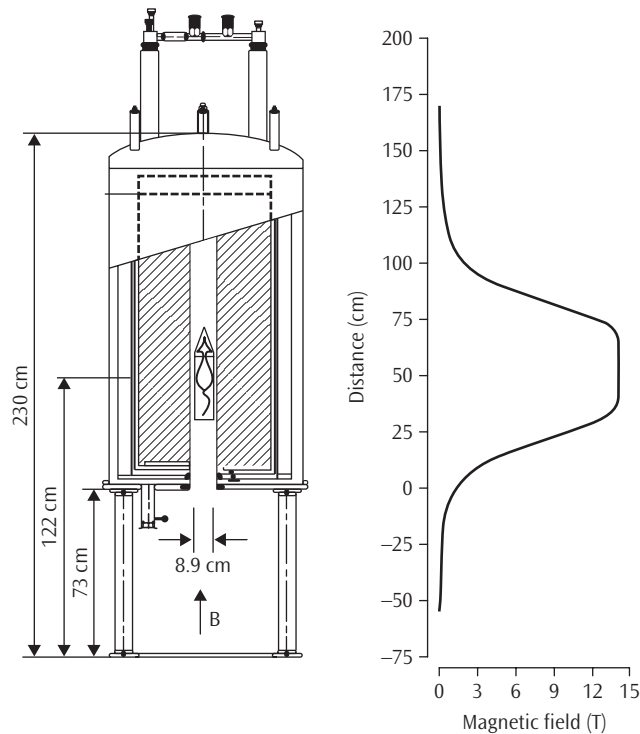

Figure 20.1. Cross-sectional schematic of the 14.1-T superconducting magnet (a) and the corresponding magnetic field (b) relative to the opening of the magnet's bore at 0 cm. Rats were restrained in Plexiglas cylinders and inserted vertically within the bore. Note that while the maximum field is found at the center of the magnet, there are large magnet field gradients (T/m) where the magnetic field strength is rapidly changing. Maximum effects on CTA and other measures were induced, however, when the rats were within the uniform 14.1-T field that extends approximately 15 cm around the center of the magnet's bore.

at the NHMFL. After 10 days on a schedule of water restriction, the rats are given 10-min access to a novel sweet solution of either 3% glucose and 0.125% saccharin (G + S) or 0.125% saccharin alone. Rats are then individually restrained in 6-cm diameter Plexiglas tubes—very similar to the restraint used for exposure to ionizing radiation—and placed inside one of the large magnets at the NHMFL, typically for 30 min of exposure to the magnetic field. (Because of the relatively small bores of most magnets, only one rat can be conditioned at once.) Control rats are restrained but not exposed to a magnetic field.

At the end of exposure, rats are released into a large polycarbonate cage ( $37 \times 47 \times 20$  cm) with bedding and their locomotor behavior is videotaped for 2 min. When rats are removed from the magnet, they typically display two distinct and abnormal behaviors (Haupt et al., 2003). Compared to sham-exposed rats, magnet-exposed rats show

less rearing within the novel chamber (i.e., raising both forepaws from the floor of the cage to stand on their rear legs at the side of the chamber.) Furthermore, magnet-exposed rats tend to walk in tight, counterclockwise circles with a diameter of less than a body length. The tendency to circle is even more evident when rats are exposed within a magnet then placed in a swimming pool to provoke locomotion (see Figure 20.2; see also color Figure 20.2 in the Color insert). These immediate effects of magnet exposure are transient and usually end within 2 min. They are in sharp contrast, however, to ionizing radiation, in which there were no visible signs of a disturbance in behavior following irradiation.

Because magnetic fields are a novel type of US, we have taken pains to establish that the CTA induced by magnetic fields fulfill the basic criteria for CTA learning. Control groups that were given a sweet taste CS and then either exposed within a



*Figure 20.2.* Traces of individual rats swimming in 2-m diameter pool after 30-min exposure to 14.1 T (thin line) or sham exposure (thick line). The first 50 s of swimming are shown. Exposure to high magnetic fields induces walking in tight circles within an open field; the circling is more apparent when provoked in a swim test. The circling is transient and usually subsides within 2 min.

“sham-magnet” (a vertical PVC tube placed outside the 5-gauss line of the NMR magnets) or exposed to 0 T within an unenergized resistive magnet do not acquire a CTA. Thus, the association of taste and magnetic field exposure is specific to the presence of a strong magnetic field and not to the exteroceptive stress of restraint or the environs of the magnets’ bore.

The acquisition of the CTA is also specific to the taste used at the time of pairing. As a CS, we used 10-min access to sweet solutions of either G + S or 0.125% saccharin. Control rats that received 10-min access to distilled water prior to 10-min exposure to the 14.1 T magnetic field showed a robust preference for novel G + S in subsequent two-bottle preference tests. Thus, decreased preference for G + S or saccharin is not a persistent effect of magnetic field exposure on sweet taste preference, but it requires the contingent association of the novel taste with magnetic field exposure.

## LONG INTERSTIMULUS INTERVAL

A cardinal feature of CTA learning is that it can be induced even when there is an exceptionally long interval between exposure to the taste and US treatment. For example, significant CTA has been induced when saccharin consumption was paired with X-radiation after a 12-h delay. Magnetic-field-induced CTAs also tolerate a long delay between taste and magnetic field exposure. A short delay between CS and US has always been obligatory, because the rats usually received their 10-min access to the CS in the NHMFL animal facility some 50 m from the superconducting magnets. Thus there has always been at least a 1–2 min delay after the end of CS access while the rats are placed in the restraint tube, transported to the magnet room, and introduced into the core of the magnet. Even a 2-min interstimulus interval places the phenomenon outside the range of most forms of classical conditioning (reviewed in Kimble, 1961).

More formally, we gave water-restricted rats access to G + S solution for 10 min, paired with 10-min exposure to 14.1-T magnetic field at varying intervals before or after G + S access (T. A. Houpt & J. C. Smith, unpublished data). CTA was accessed with 24-h, two-bottle preference tests. No CTA was observed after backward conditioning (i.e., when magnetic field exposure preceded CS access.) Significant CTA was observed when magnetic field exposure occurred immediately after CS access or 1 h (but not 3 h) after CS access. Thus, magnetic-field-induced CTA also tolerates a long delay.

## GRADED EFFECTS OF MAGNETIC FIELD EXPOSURE

An important test of specificity for any treatment is the demonstration of graded effects, along with the determination of the minimal threshold for producing a reliable effect. For magnetic fields, there are three dimensions along which graded effects can be determined: intensity or strength of the magnetic field, duration of exposure to the magnetic field, and number of pairings of the CS with the magnetic field.

We demonstrated a “dose–response” curve for the intensity of high magnetic fields in three ways (see Figure 20.3). First, by exposing different rats to the core of three different superconducting magnets (7, 9.4, and 14.1 T; Houpt et al., 2003); second, by

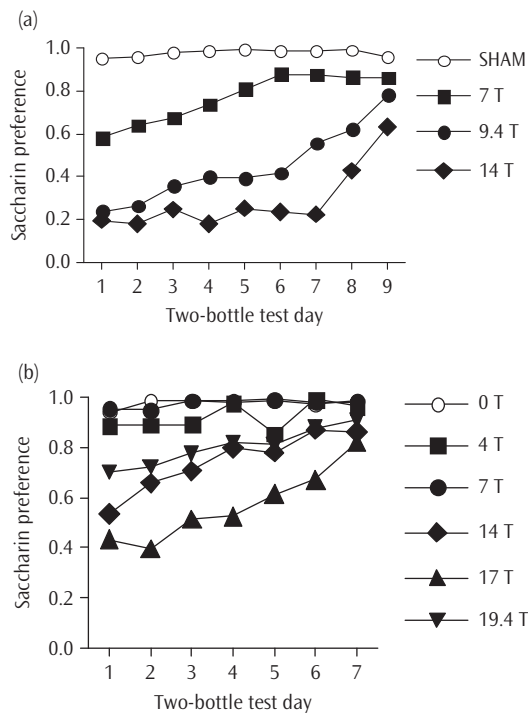

**Figure 20.3.** Magnitude and persistence of CTA is proportional to magnetic field strength, as shown by extinction during consecutive 24-h, two-bottle preference tests. (a) Extinction curves after three pairings of 10-min access of G + S with 30-min exposure within 7 T, 9.4 T, or 14 T superconducting magnets. Repeated pairings with 7 T were sufficient to significantly decrease G + S preference. (b) Extinction curves after one pairing of 10-min access of G + S with 30-min exposure within a 0–19.4-T magnetic field of a resistive magnet. Maximal CTA was observed after 17-T exposure.

exposing different rats in a resistive electromagnet at various current levels (4, 7, 9, 11, 14, 17, and 19.8 T; Houpt et al., 2005); and, third, by exposing different rats at different positions within the magnetic field of a 14.1-T magnet (0.05–14.1 T; Houpt, Cassell, Cason, et al., 2007). The thresholds for behavioral effects are consistent across these three studies: at 3–4 T and above, circling was induced and rearing was suppressed. Acquisition of a maximal CTA (e.g., an average saccharin preference score of 0.1–0.2) required a single pairing with exposure to at least 14 T for at least 30 min, or three pairings with exposure to 7 T for 30 min. (A weaker CTA

was observed after 19.4 T exposure; in fact, rats looked somewhat stunned and were immobile for several seconds immediately after 19.4-T exposure, and so perhaps nonspecific aversive effects interfered with CTA acquisition.) Importantly, the consistent replication of stimulus thresholds across different experimental preparations and different magnets eliminates the possibility that the observed effects are artifacts of procedure or equipment.

In our experiments, we generally exploited magnetic fields much larger than those used clinically to ensure robust responses. It is relevant, therefore, to determine the minimal field intensity that produces behavioral effects. In the case of CTA, we found that a single pairing of saccharin with 30-min exposure to a magnetic field as low as 0.05 T (within the fringe field of the 14.1-T magnet) was sufficient to produce a small CTA (i.e., a statistically significant decrease in saccharin preference from 0.95 to 0.7). This effect was small and only detected with a large group of rats ( $n = 16$ ), but it suggests that we may be able to extrapolate the effects of high magnetic fields to lower magnetic fields more typical of clinical situations (Houpt, Cassell, Cason, et al., 2007).

#### DURATION OF MAGNETIC FIELD EXPOSURE

As with ionizing radiation, the duration of magnetic field exposure is also important. In a parametric experiment, rats were given a single pairing of G + S intake with 0–30-min exposure to the 14.1-T magnetic field (Houpt et al., 2003). There was a significant effect of the duration of exposure to the 14.1-T magnetic field on the number of rats circling and rearing. Counterclockwise circling was induced by exposures of 5 min or longer; rearing was significantly reduced after only 1 min of exposure. Two-bottle preference testing showed that rats that received 1-min, or longer, exposure had significantly lower preference for G + S compared to rats that received 0-min exposure. However, longer exposures to 14.1 T produced stronger aversions for G + S that extinguished more slowly.

#### NUMBER OF PAIRINGS

As with other CS–US paradigms, repeated pairings of CS and magnetic field exposure results

in stronger CTA learning. Compared to a single pairing, three pairings of G + S with 30 min of exposure to either 7, 9.4, or 14.1-T magnetic fields produced stronger and more persistent CTAs (Haupt et al., 2003). Rats had only 10-min access to a single bottle of G + S across the three conditioning days, but even so significant decreases in G + S consumption were seen across days. A graded effect was also seen in extinction. For example, a significant CTA after a single pairing of G + S with 14.1 T persisted for 2 days of two-bottle testing, while the CTA after three pairings persisted for 8 days.

### ORIENTATION WITHIN THE MAGNETIC FIELD

Magnetic field strength is determined by the density of magnetic flux lines; within the bore of the superconducting and resistive magnets, the flux lines are oriented parallel to the vertical (longitudinal) axis of the bore. We found that the orientation of the rat relative to the field is significant for behavioral effects. Because the superconducting magnets have bores that are only 89 mm in diameter, rats can only be placed with their rostral-caudal body axis parallel to the magnetic field. When placed head-up in the magnet, the rats face +B (equivalent to the magnet's south pole). They can also be placed head-down, facing -B (equivalent to the magnet's north pole). Equivalent CTAs are produced when the CS is paired with 30-min exposure to 14.1 T in either orientation. However, rats placed head-up circled exclusively counterclockwise, while rats placed heads-down circled exclusively clockwise (Haupt et al., 2003).

The source of this asymmetry is unknown. It appears to be a property of the rat's relative orientation and not an effect of heads-down restraint, because the same results were found when rats were restrained in the large resistive magnet in the heads-up position (Haupt et al., 2005). Because the orientation of the field within the resistive magnet can be reversed by reversing the polarity of the applied DC current, rats were exposed heads-up to either +14.1 T or -14.1 T. Again, a comparable CTA was induced, but rats exposed to +14.1 T circled exclusively counterclockwise and rats exposed to -14.1 T circled exclusively clockwise.

The larger 189-mm bore of the resistive magnet also allowed us to orient rats with their

rostral-caudal axis perpendicular to a 14.1-T magnetic field (Haupt et al., 2005). Surprisingly, after 30-min exposure in this horizontal orientation, only one of six rats circled. Furthermore, while half the rats showed a decreased preference for G + S, as a group no significant CTA was acquired. Thus it appears that a rostral-caudal orientation parallel with the high magnetic field is required to elicit full behavioral responses. (Note that this is the typical orientation of patients in MRI machines as well.) This may be a significant clue as to the interaction of the magnetic field with possible receptive organs, such as those components of the vestibular apparatus that are oriented approximately orthogonally to the major body axes.

### CONSTANT FIELD VERSUS FIELD GRADIENT

Large magnets can not only produce a constant and homogenous magnetic field at their core, but they can also necessarily produce fringe fields with high gradients that drop off rapidly away from the core. Exposure to high gradients or movement of a conductor such as rat tissue through magnetic fields has the potential to generate electric currents that could stimulate the tissue (Halliday & Resnick, 1986). Our data suggests that the behavioral responses to magnet exposure depends on prolonged exposure to the constant high-magnitude magnetic field at the core and not simply on transient passage through the field or exposure to severe magnetic field gradients. Thus, CTA, circling, and suppression increase with time spent (1–30 min) at the center of the 14.1-T magnet while transient passage through the field has no effect (Haupt et al., 2003). Likewise, compared to exposure within the uniform field at the core, exposure to the large gradients (but lower fields) outside the core was not as effective as a US for CTA learning (see below; Figure 20.5; Haupt, Cassell, Cason, et al., 2007). The effects of continuous motion into or within high-strength static magnetic fields have not been evaluated, however.

The dependence on a static uniform field is surprising, however, because translational force (i.e., a pull toward the magnet) is imposed on magnetic objects only when the object is within a field gradient (i.e., outside of the core of the magnet). Within the uniform magnetic field at the core of the magnet, no net translational force will be experienced.

Although translational force would not be experienced within the core, torque would be applied to magnetic substrates within the rat that were not parallel with the uniform magnetic field (Halliday & Resnick, 1986). Alternatively, small motions of the rat's head while restrained within a static field could generate perceptible forces within receptive organs. For example, Schenck has proposed that movement of the inner ear could generate a magneto-hydrodynamic force on the charged endolymph of the semicircular canal, thus stimulating the vestibular system and inducing motion sickness (Schenck, 1992).

#### PARALLELS BETWEEN VESTIBULAR AND MAGNETIC STIMULATION

A link between magnetic fields and the inner ear is suggested by several parallels between the effects of high magnetic fields and the effects of vestibular stimulation or perturbation. The subjective experience of magnetic field exposure may be similar to vestibular perturbation; there are two published reports (and many anecdotes) of vertigo and nausea in humans working around 4-T and 8-T MRI machines (Kangarlu et al., 1999; Schenck et al., 1992). As with magnetic field exposure, pairing a novel flavor with subsequent vestibular stimulation can induce a CTA. The central vestibular system integrates labyrinthine, visual, and proprioceptive inputs to maintain posture and gaze. Aberrant sensation from one input that does not match the other two inputs leads to subjective reports of motion sickness, as well as correlates of malaise in animals such as emesis and pica. Thus, vestibular stimulation can serve as a very effective but nontoxic US for CTA acquisition.

#### VESTIBULAR INDUCTION OF CTA

CTA can be induced either with constant whole-body rotation (Green & Rachlin, 1973; Haroutunian & Riccio, 1975; Hutchison, 1973), which stimulates mostly the otolith organs of the inner ear by simulating "hypergravity," or with time-varying whole-body rotation (Cordick, Parker, & Ossenkopp, 1999) or compound rotation off-axis (Braun & McIntosh, 1973; Fox, Lauber, Daunton, Phillips, & Diaz, 1984)—both of which strongly stimulate the semicircular canals by constantly altering the

angular velocity. Rotation of the visual field while the subject remains stationary (optokinesis) can also induce CTA in humans (Klosterhalfen et al., 2000; Okifuji & Friedman, 1992).

We examined the magnitude of rotation-induced CTA in our paradigm using constant, off-axis rotation as the US. Water-restricted female rats were given 10-min access to G + S and then restrained on a motor-driven boom at 0, 4, 28, and 49 cm from the center of rotation ( $n = 8$ /group). The rats were rotated in the horizontal plane (around a dorsal-ventral axis) for 10 min at 60 RPM. The next day, 24-h two-bottle tests were begun to measure CTA expression. The effects of rotation were dependent on the radius of rotation. Constant-speed rotation at or near the center had little or no effect on locomotion and did not induce CTA. At higher radii, rotation induced greater CTA (see Figure 20.4) and suppressed rearing more completely. In addition, rats were also rotated at lower (40 RPM) and higher (120 RPM) speeds, and around the medial-lateral axis or rostral-caudal axis. The same general results were found: regardless of the axis of rotation, greater CTA occurred at greater hypergravity (at higher radii or speed). Similar results were obtained by others for the effects of speed and duration of rotation (Green & Rachlin, 1976).

Vestibular stimulation also has an unconditioned effect on intake. Water-deprived rats show water consumption after whole-body rotation

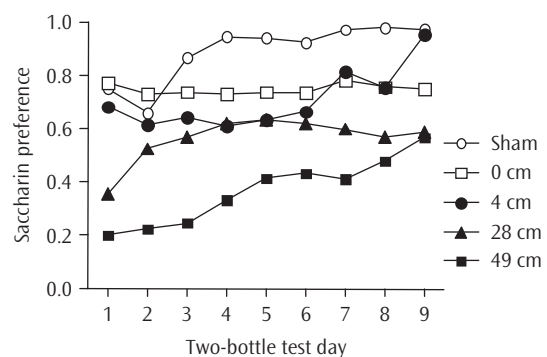

Figure 20.4. CTA extinction after pairing saccharin with sham restraint, or 10-min rotation in the horizontal plane at 60 RPM at 0, 4, 28, or 49 cm radius. Greater radius of rotation causes increased "hypergravity," which stimulates the otolith organs and induced stronger CTA.

(Haroutunian, Riccio, & Gans, 1976; Sutton, Fox, & Daunton, 1988), correlated perhaps with postrotatory postural problems or hypoactivity that would conflict with drinking behavior (Ossenkopp, Rabi, Eckel, & Hargreaves, 1994). Similarly, we found that exposure to 14.1-T magnetic field decreases novel G + S intake by thirsty rats from bottles, largely by increasing the latency to initiate licking (Haupt, Cassell, Riccardi, Kwon, & Smith, 2007). When novel G + S was presented directly into the mouth through intraoral catheters, however, magnetic field exposure had no effect on intake, consistent with a postural effect on ad lib drinking from bottles.

### LOCOMOTOR CIRCLING

The circling displayed by rats after magnetic field exposure immediately suggested an asymmetrical effect of the magnetic field on the vestibular system. Destruction (e.g., by unilateral labyrinthectomy [LBX]) of the inner ear leading to asymmetrical labyrinthine inputs also causes pronounced circling behavior in rodents, with turning toward the lesioned ear. Likewise, circling is a common behavioral symptom of rodents with mutations of the inner ear. Although intact rats do not spontaneously walk in circles following whole-body rotation, when provoked by a swim test they display a postrotatory effect by swimming in circles opposite to the direction of rotation (Semenov & Bures, 1989).

There are many other behaviors regulated by the vestibular system that we have not systematically investigated in the context of magnetic field exposure. For example, we have consistently observed "head bobbing" and nystagmus in the rats after magnetic field exposure, but we have not yet quantified these behaviors. Because a critical function of the vestibular system is head and gaze stabilization via the vestibulo-ocular reflex, perturbation of this reflex is another suggestive parallel.

### C-FOS IN VESTIBULAR RELAYS

The immediate early gene product c-Fos is commonly used to map neural structures that are activated by the US and CS in CTA paradigms (Haupt, Philopena, Joh, & Smith, 1996a, 1996b; Haupt, Philopena, Wessel, Joh, & Smith, 1994; Swank &

Bernstein, 1994; Swank, Ellis, & Chochran, 1996; Swank, Schafer, & Bernstein, 1995). The c-Fos protein is expressed at a very low constitutive level in many brain structures. Following US or CS stimulation of the animal, however, transynaptic activation of second messenger cascades causes the rapid but transient synthesis of c-Fos protein within 30–180 min. The c-Fos protein is easily visualized by immunohistochemistry and its labeling is discretely localized within cell nuclei. Quantification of the number of c-Fos positive cells provides a measure of response magnitude. Thus, the presence of c-Fos after stimulation in a central relay implies direct or indirect activation of the relay by the stimulus. (An important caveat in the interpretation of c-Fos patterns is that not all neurons express c-Fos after stimulation, and so it is assumed that only a subset of activated neurons are visualized.)

Consistent with high magnetic fields serving as a US in CTA acquisition, 30-min exposure to 9.4-T or 14.1-T magnetic field induced significant c-Fos in visceral relays such as the nucleus of the solitary tract (NTS) and the lateral parabrachial nucleus (IPBN; Snyder et al., 2000). Both the NTS and the IPBN are activated by treatments frequently used in CTA learning, such as systemic LiCl administration. Unlike LiCl, however, high magnetic field exposure also induced significant c-Fos in vestibular relays of the brainstem, such as the medial vestibular nucleus, prepositus nucleus, and supragenualis nucleus. Little or no c-Fos was observed in control rats restrained for 30 min in a "sham-magnet." The c-Fos induction was a consequence of magnetic field exposure and not caused by the magnet-induced locomotor circling, because c-Fos was still expressed in magnet-exposed rats that were prevented from circling by an extra 15 min of restraint.

The pattern of neural activation after magnetic field exposure also parallels the response to vestibular stimulation. These c-Fos results, however, can be interpreted in two additional ways. First, input from specific parts of the labyrinth can be inferred from activation in the projection sites of afferents. Tracing studies have identified specific afferent projection sites (Newlands & Perachio, 2003), for example, the utricle innervates the medial vestibular nucleus but the saccule innervates the superior vestibular nucleus. Second, a considerable database of c-Fos activation by vestibular stimuli has been established by other investigators (simplified and

Table 20.1 Induction of c-Fos in Brainstem Nuclei after Magnetic Field Exposure or Vestibular Treatments.

Brainstem Nuclei	Magnetic Field Exposure	Off-Axis Rotation (Otolith)	Sinusoidal Rotation (Semicircular)	VOR Adaptation (Lateral Canal)	Unilateral LBX (Otolith and Semicircular)
MeV	+	+	–	+	+
Prp	+	–	+	+	+
IO $\beta$	+	–	+	–	+
DMCC	+	+	–	–	+
IOK	+	–	–	+	+

Source: Kaufman (2005).

Notes: Afferent pathways affected are indicated parenthetically. VOR, vestibulo-ocular reflex; MeV, medial vestibular nucleus; Prp, prepositus nucleus; IO $\beta$ , inferior olivary complex beta; DMCC, dorsomedial cell column; IOK, inferior olivary complex kappa. +, c-Fos induced by treatment; –, c-Fos not induced.

summarized in Table 20.1). Again, discrete c-Fos patterns are seen to be correlated with stimulation of specific inner ear organs (Kaufman, 2005). In some cases, exclusive c-Fos patterns are induced by different treatments (e.g., off-axis vs. sinusoidal rotation). Conversely, unilateral LBX induces widespread and overlapping c-Fos expression.

Comparison of these patterns with magnetic-field-induced c-Fos in intact rats shows correlations with specific vestibular pathways (Table 20.1). Thus, the magnetic-field-activated brain stem looks similar to the pattern of innervation by both utricular and semicircular afferents, or to c-Fos induction in response to a compound stimulation of both classes of afferents (e.g., unilateral LBX).

#### SITE OF ACTION FOR MAGNETIC FIELDS

While these parallels suggest an interaction with the vestibular system, the peripheral sites of interaction or detection by magnetic fields are unknown. Typically, the analysis of receptive sites for a stimulus would include the focal stimulation of specific parts of the body. Focused or site-specific application is straightforward for many categories of sensory stimuli and has defined receptive sites in many systems. As described above, during the investigation of the detection of ionizing radiation by mammals, it was possible to limit irradiation of rats or monkeys to either the abdomen or the head using focal X-ray machines or by employing lead shielding to limit exposure. The necessary roles of the abdomen, olfactory system, and retina were subsequently confirmed by pharmacological

blockade of histamine in rats (Levy et al., 1974) and by ablation studies in rats (Dinc & Smith, 1966), monkeys (Chaddock, 1972), and other species (Smith, 1971).

Thus, in the analysis of magnetic field effects it would be helpful to limit exposure to specific somatic regions, for example, the abdomen versus the head. Unfortunately, it is impossible to shield against magnetic fields in the higher range typical of MRI machines. There is no substance that is opaque to these higher magnetic fields as those that exist for electromagnetic radiation (e.g., lead for X-rays), nor are there ways to limit magnetic fields as those that exist for interfering electric fields (e.g., a Faraday cage). The fringe of the high magnetic fields generated by NMR or MRI machines typically falls off across meters, rather than the centimeters needed for localization in rodents. Indeed, it may be this gradient of the magnetic field that imposes a differential field across a region of the rat's body and thereby induces the responses of circling and CTA reported above.

In order to approximate site-specific exposure to the high magnetic field, we placed rats at different positions along the bore of the 14.1-T superconducting magnet (Haupt, Cassell, Cason, et al., 2007). By measuring the current induced in a copper coil pulled through the magnet at a constant speed (see methods below), we mapped the strength of the magnetic field with 1 mm resolution along the center of the magnet's 89-mm bore (see Figure 20.1). It can be seen that the magnet has a uniform central field ( $B_0$ ) of 14.1 T for a distance of approximately 35 cm in the center of the bore. Along the vertical axis there is a steep field gradient ( $dB/dz$ ), which reaches a maximum of 56 T/m.

Rats were restrained in Plexiglas restraint tubes and stacked within the bore of the magnet for 30-min exposures. Exposure of the body and head was roughly limited to one or both of the two salient components of the magnetic field: the uniform center of constant 14.1 T or the steep gradient above and below the maximum magnetic field. By varying the vertical position within the bore, rats could be exposed such that (1) both the head and the body would be exposed to the uniform, maximal magnetic field at the center; (2) the head would be exposed in the center to 14.1 T while the body would be in the steep gradient, or vice versa; or (3) both the head and the body would be in the steep gradient above or below the maximal magnetic field at the center.

The results indicated that exposure of the head is necessary for maximal effects of the magnetic field (see Figure 20.5; see also color Figure 20.5 in the Color insert). For example, rats exposed just below the peak magnetic field intensity (at 35 cm, with caudal body at 7 T and head at 14.1 T) showed robust circling and CTA acquisition, while rats exposed just above the peak magnetic field intensity (at 95 cm, with caudal body at 10 T and head at 3 T) showed much weaker responses.

Significantly, the magnetic field effects appeared unrelated to the vertical gradient of the magnetic field experienced by the rats. In the preceding example, both groups of rats positioned at 35 cm and 95 cm within the bore of the magnet experienced large rostral-caudal gradients (20.1 T/m and  $-30.2$  T/m, respectively), yet a much greater response was seen in rats exposed at 35 cm.

#### EFFECTS OF CHEMICAL LBX

The similarity of responses induced by magnetic exposure or vestibular stimulation and the sensitivity of the rostral body suggest that the vestibular apparatus of the inner ear is acted upon by high magnetic fields. Therefore, we examined the effects of chemical LBX by intratympanic injection of sodium arsenilate. Sodium arsenilate causes a near complete destruction of the vestibular apparatus, although it is nonspecific and destroys both otolith and semicircular organs, as well as the auditory cochlea (Anniko & Wersäll, 1977). The effects of vestibular stimulation on behavioral and neural responses largely depend on an intact inner

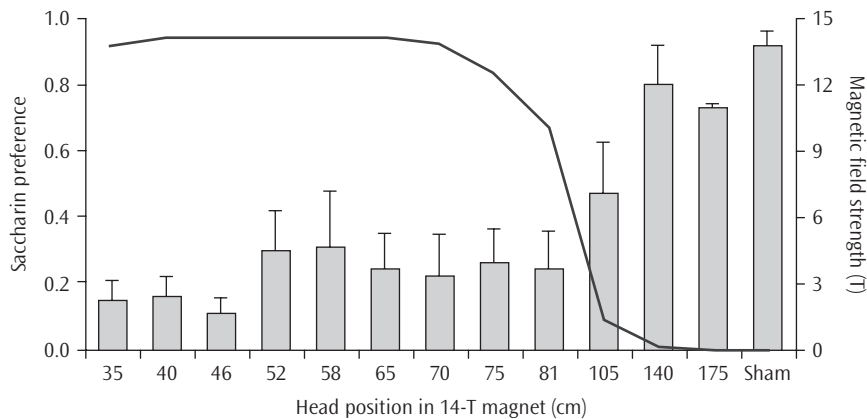

*Figure 20.5.* Maximal CTA is induced by exposing the head to the maximum uniform field. Rats were “stacked” within the bore of the 14.1-T magnet at different positions, such that their heads (i.e., 65 cm) or their caudal body (i.e., 105 cm) was exposed to the maximum uniform field at the center, or so that they were exposed to the maximum field gradient (i.e., at 105 and 140 cm). The strength of the magnetic field at different positions within the 14.1-T magnet is indicated by the line; magnitude of CTA expressed on the first day of two-bottle testing after exposure at different positions is indicated by the bars. Large CTA was only acquired when the rostral body was exposed to 14.1 T. On the basis of rate of extinction (not shown), the greatest CTA was induced at 65 cm where the entire body was exposed to 14.1 T. Exposure to a large gradient produced little or no CTA, however.

ear. Thus, the effects of whole-body rotation on decreased activity (Ossenkopp et al., 1994), CTA acquisition (Ossenkopp et al., 2003), and c-Fos induction (Kaufman et al., 1992) are abolished by bilateral chemical LBX.

Adult female rats were injected intratympanically with sodium arsenite (15 mg/50  $\mu$ l) or saline. LBX was validated by inverting the rats and allowing them to walk upside-down on a Plexiglas sheet apposed to their feet. Two weeks later, the effects of magnetic field exposure (14.1 T for 30 min) on circling, CTA, and c-Fos responses were tested.

After sham exposure, sham-operated rats ( $n = 6$ ) showed little or no circling and some rearing. LBX rats ( $n = 6$ ) showed some circling, but in clockwise and counterclockwise directions. Following magnet exposure, sham-operated rats showed a significant increase in counterclockwise circling, and a significant decrease in rearing. LBX rats, however, did not show an increase in circling nor a decrease in rearing (see Figure 20.6a).

#### CTA ACQUISITION AFTER LBX

To assess the effects of LBX on CTA acquisition, additional sham-operated and LBX rats were placed on a schedule of water restriction. On conditioning day, rats were given 10-min access to 0.125% saccharin, then restrained and exposed to 14.1-T magnetic field or sham exposed for 30 min ( $n = 6$  in each of four groups). On subsequent days, rats received another two pairings of saccharin and exposure. After the last pairing, rats were given 24-h two-bottle preferences tests of saccharin versus water daily until the CTA extinguished. As expected, sham-exposed rats of either surgical group formed no CTA, while sham-operated rats after magnet exposure showed a significant CTA that slowly extinguished. LBX rats showed no CTA at all, however (see Figure 20.6b). These results suggest that the inner ear is a critical site of magnetic field effects capable of inducing CTA.

#### C-FOS INDUCTION AFTER LBX

Finally, to determine if neural activation by magnetic field exposure depended on the inner ear, sham-operated and LBX rats were exposed to 14.1 T or sham exposed for 30 min, then perfused 1 h after the end of exposure, and their

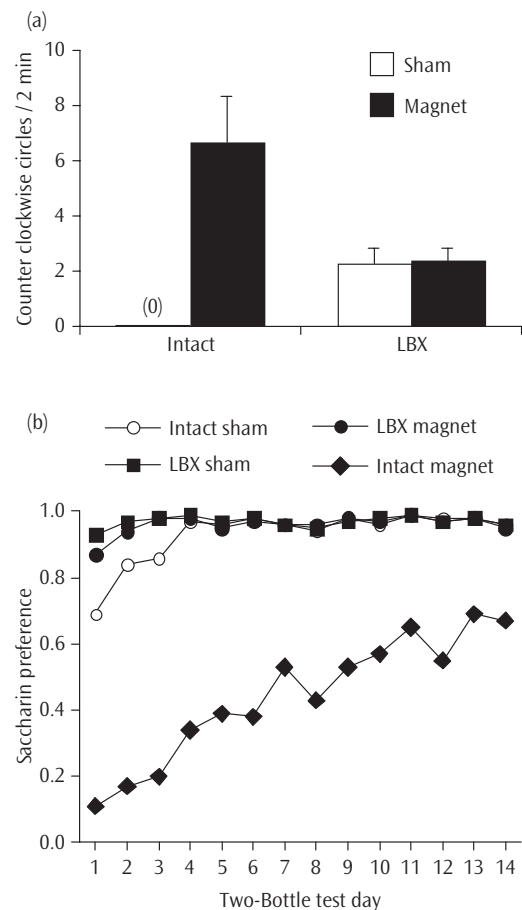

Figure 20.6. (a) Circling in intact and labyrinthectomized (LBX) rats. Intact rats do not spontaneously circle after sham exposure, but walk in tight circles after 14.1 T magnetic field exposure. While LBX rats spontaneously circled after sham exposure, magnetic field exposure did not increase their circling activity. (b) CTA acquisition by intact but not LBX rats. After three pairings of saccharin and 30-min exposure to the 14.1-T magnetic field, intact rats formed a strong CTA that extinguished only gradually. Saccharin preference of LBX rats exposed to the magnetic field was indistinguishable from the preference of sham-exposed rats without a CTA.

brainstems processed for c-Fos immunoreactivity. Quantification of c-Fos positive cells showed that 14.1-T magnetic field exposure (but not sham exposure) induced significantly more c-Fos positive cells compared to sham exposure in brainstem

vestibular and visceral nuclei. In LBX rats, however, c-Fos levels were not different from sham-exposed rats. Thus the inner ear is a critical site for magnetic field effects that cause neuronal activation of the brainstem.

Although the inner ear appears critical, other sensory pathways may be necessary or contribute to visceral stimulation mediating CTA acquisition after magnetic field exposure. The other two major pathways contributing to CTA learning are subdiaphragmatic vagal afferents (which detect toxins affecting the gut; Coil, Rogers, Garcia, & Novin, 1978) and the chemoreceptive area postrema (which detects toxin-induced humoral factors or blood-borne toxins; Ritter, McGlone, & Kelley, 1980). These pathways also contribute to rotation-induced CTA (Fox & McKenna, 1988; Gallo, Arnedo, Aguero, & Puerto, 1991; Ossenkopp, 1983). Furthermore, because the vestibular system integrates sensation from the eyes, inner ear, and proprioceptors, visual and proprioceptive sensation are likely to contribute to magnetic-field-induced CTA.

#### USE OF INNER EAR MUTANTS

Chemical LBX abolished every effect of high magnetic fields: suppression of rearing, locomotor circling, CTA acquisition, avoidance of high magnetic fields, and vestibular c-Fos induction. Thus, the inner ear is critical to the reception of high magnetic fields by the rat. Chemical LBX, however, destroys all hair cells within the inner ear. Thus it remains unknown if the magnetic field is transduced by the semicircular canals or otolith organs. Unfortunately, ablation of specific vestibular organs (e.g., removal of just otolith organs or plugging of individual semicircular canals) is very difficult in small rodents such as rats; we are unable to use rodents with larger heads and a more accessible inner ear (e.g., chinchilla; Hirvonen, Carey, Liang, & Minor, 2001) because of the small bore size of our large magnets.

To distinguish the contribution of the various parts of the inner ear, therefore, we have begun to screen mutant mouse strains with vestibular disorders. Although many vestibular mutants have nonspecific or gross malformations of the inner ear, it is possible to find some strains with relatively specific deficits in otolith organs (e.g., pallid [*pal*], head-tilt [*bet*] mice, and tilted-head

[*tlt*] mice; Jones, Erway, Johnson, Yu, & Jones, 2004) or semicircular canals (e.g., epistatic circler [*ec*]; Cryns et al., 2004) or fidget [*fi*] mice; Cox, Mahaffey, Nystuen, Letts, & Frankel, 2000). Disadvantages of this approach are familiar from the transgenic literature: the mutations exist from conception so that long-term effects or compensation may have occurred; the mutations are irreversible, so that they may modulate both reception during magnetic field exposure and expression of magnetic field effects on subsequent testing; and the mutations may cause unknown deficits in the rest of the body.

Our preliminary findings with *bet* mice (indicating a necessary role for otoconia) suggest that this approach will be informative. A swim test was used to phenotype *bet* mice and their littermates. Wildtype mice (+/+) swam toward the side of the pool. Homozygous *bet* mice (*bet/bet*) were identified by their inability to swim while keeping their head above water; instead, they swim in circles and “somersault” downward underwater. Heterozygotes (*bet/+*) were identified by an intermediate phenotype. Mice were placed on a schedule of water restriction. On three consecutive days, mice were given 10-min access to 0.125% saccharin followed by 30-min restraint within the core of the 14.1-T magnet or by sham exposure, for a total of three pairings. CTA expression was assessed in two-bottle preference tests (see Figure 20.7). While wildtype mice acquired a significant CTA, the saccharin preference of magnet-exposed *bet/bet* and *bet/+* mice was not significantly different from sham-exposed mice. The failure to acquire a magnet-induced CTA was not due to a generalized learning deficit, because all *bet* mutant mice were able to acquire a LiCl-induced CTA (data not shown).

#### CONCLUSION

On the basis of direct observation of postexposure behaviors and the expression of CTA, we have identified graded and specific behavioral responses induced by high static magnetic fields. These effects have been reliably observed with magnetic fields as low as 7 T, which is within the range of MRI machines used for human imaging (Kangarlu et al., 1999). The induction of c-Fos expression in the brain represents neural activity secondary to exposure to magnetic fields, and suggests activation of both visceral and vestibular circuits. Because the

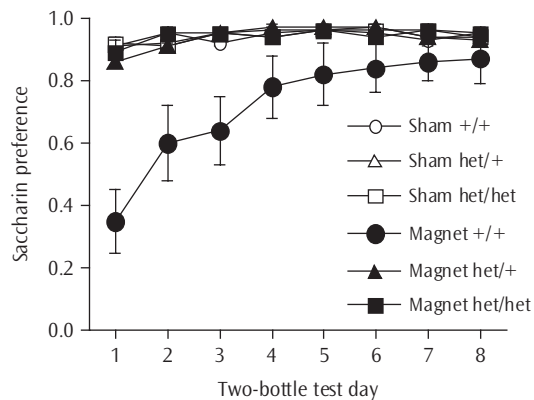

Figure 20.7. CTA in wildtype and head-tilt (*het*) mutant mice. After three pairings of saccharin with exposure to 14.1 T (black symbols), wildtype mice (+/+) acquired a significant CTA. Neither heterozygous (*het*/+) nor homozygous mutants (*het/het*) showed CTA after magnetic field exposure.

magnetic field exposure can serve as a US for CTA acquisition, and because exposure appears to perturb the vestibular system, our results may serve as an animal model for the anecdotal reports of vertigo and nausea around large magnets (Kangarlu et al., 1999; Schenck et al., 1992).

Chemical LBX abolished all the observed effects of magnetic fields, and therefore the vestibular apparatus appears to be the receptive organ. On the basis of our finding that mutant mice lacking otoconia do not respond to magnetic fields, we hypothesize that the magnetic field may interact with the vestibular system via the otolith organs, potentially on the calcium carbonate crystals within the otoconia themselves. Calcium carbonate has a magnetic susceptibility of  $-38.2 \times 10^{-6}$  cgs; higher than the susceptibility of calcium hydroxyapatite in bone ( $0.9 \times 10^{-6}$  cgs; Hopkins & Wehrli, 1997), but far lower than the susceptibility of ferromagnetic crystals such as  $\text{Fe}_2\text{O}_3$  ( $7200 \times 10^{-6}$  cgs).

Beyond the delayed effect of magnetic fields to induce CTA, there are two additional areas of investigation that we are pursuing. First, as with ionizing radiation, it appears that rats are capable of immediately and consciously detecting the presence of a strong magnetic field. In order to demonstrate immediate detection, we used an operant-type task (Haupt, Cassell, Riccardi, et al., 2007).

Rats were trained to climb up the inside of a 10-m long cylinder made of plastic mesh to reach a food reward at the top. Rats easily learned to climb the “ladder” when it was positioned outside of a magnetic field. When the ladder was inserted through the center of the 14.1-T superconducting magnet, however, rats climbed through the bore of the magnet at most only one time, and on subsequent tests refused to enter the bore of the magnet. Thus they appeared able to detect the presence of the magnetic field, and avoided entry after only one exposure to the center of the magnet. This immediate detection of the magnetic field was also dependent on the vestibular system, because labyrinthectomized rats readily and rapidly climbed the ladder through the 14.1-T magnetic field. As was done with ionizing radiation, we are exploring the immediate detection of magnetic fields using a conditioned suppression apparatus that is adapted for the application of a high magnetic field across the rat’s head during an operant task (e.g., licking). Thus, unlike the case of ionizing radiation in which CTA induction and immediate detection were mediated by different receptor systems, CTA and immediate detection both appear to be transduced by the inner ear.

Second, we have consistently observed a diminished response to the magnetic field after repeated exposures. For example, the amount of locomotor circling is highest after the first 30-min exposure to 14.1 T, but decreases after the second and third exposure. Conversely, the amount of rearing increases across exposures (Haupt et al., 2003, 2005). The diminished response could be a form of sensory habituation. We found, however, that the diminished responsivity is very persistent: if rats are preexposed for 30 min to 14.1 T twice, they do not circle in response to a third exposure 30 days later. We are therefore exploring the possibility that repeated exposure to high magnetic fields induces either vestibular habituation, or alternatively delivers a long-lasting perturbation to the vestibular apparatus.

*Acknowledgments* Supported by the Florida State University Research Foundation and the National Institute of Deafness and other Communication Disorders. We thank Drs. Tim Cross, Zhehong Gan, Riqiang Fu, and Bruce Brandt for assistance and continued access to the magnets of the U.S. National High Magnetic Field Laboratory.

## References

- Anniko, M., & Wersäll, J. (1977). Experimentally (atoxyl) induced ampullar degeneration and damage to the maculae utriculi. *Acta Oto-Laryngologica*, 83, 429–440.
- Arwas, S., Rolnick, A., & Lubow, R. E. (1989). Conditioned taste aversion in humans using motion-induced sickness as the US. *Behaviour Research and Therapy*, 27, 295–301.
- Barnett, S. A. (1963). *The rat: A study in behavior*. Chicago, IL: Aldine Press.
- Berardelli, A. (1991). Electrical and magnetic spinal and cortical stimulation in man. *Current Opinion in Neurology and Neurosurgery*, 4, 770–776.
- Bernstein, I. L. (1978). Learned taste aversions in children receiving chemotherapy. *Science*, 200, 1302–1303.
- Bernstein, I. L., Webster, M. M., & Bernstein, I. D. (1982). Food aversions in children receiving chemotherapy for cancer. *Cancer*, 50, 2961–2963.
- Braun, J. J., & McIntosh, H. (1973). Learned taste aversions induced by rotational stimulation. *Physiological Psychology*, 1, 301–304.
- Carroll, M. E., & Smith, J. C. (1974). Time course of radiation-induced taste aversion conditioning. *Physiology & Behavior*, 13, 809–812.
- Chaddock, T. E. (1972). Visual detection of x-ray by the rhesus monkey. *Journal of Comparative and Physiological Psychology*, 78, 190–201.
- Coil, J. D., Rogers, R. C., Garcia, J., & Novin, D. (1978). Conditioned taste aversions: Vagal and circulatory mediation of the toxic unconditioned stimulus. *Behavioral Biology*, 24, 509–519.
- Cordick, N., Parker, L. A., & Ossenkopp, K. P. (1999). Rotation-induced conditioned rejection in the taste reactivity test. *NeuroReport*, 10, 1557–1559.
- Cox, G. A., Mahaffey, C. L., Nystuen, A., Letts, V. A., & Frankel, W. N. (2000). The mouse fidgetin gene defines a new role for AAA family proteins in mammalian development. *Nature Genetics*, 26, 198–202.
- Cryns, K., van Alphen, A. M., van Spaendonck, M. P., van de Heyning, P. H., Timmermans, J. P., de Zeeuw, C. I., et al. (2004). Circling behavior in the Ecl mouse is caused by lateral semicircular canal defects. *Journal of Comparative Neurology*, 468(4), 587–595.
- Dinc, H. I., & Smith, J. C. (1966). Role of the olfactory bulbs in the detection of ionizing radiation by the rat. *Physiology & Behavior*, 1, 139–144.
- Fox, R. A., Corcoran, M., & Brizee, K. R. (1990). Conditioned taste aversion and motion sickness in cats and squirrel monkeys. *Canadian Journal of Physiology and Pharmacology*, 68, 269–278.
- Fox, R. A., Lauber, A. H., Daunton, N. G., Phillips, M., & Diaz, L. (1984). Off-vertical rotation produces conditioned taste aversion and suppressed drinking in mice. *Aviation, Space, and Environmental Medicine*, 55, 632–635.
- Fox, R. A., & McKenna, S. (1988). Conditioned taste aversion induced by motion is prevented by selective vagotomy in the rat. *Behavioral and Neural Biology*, 50, 275–284.
- Gallo, M., Arnedo, M., Agüero, A., & Puerto, A. (1991). Participation of the area postrema in learned aversions induced by body rotation. *Behavioural Brain Research*, 42, 13–23.
- Gao, B. J., Bird, M. D., Bole, S., Eyssa, Y. M., & Schneider-Muntau, H.-J. (1996). Design of a 20 T, 200 mm bore resistive magnet. *IEEE Transactions on Magnetics*, 32, 2562–2565.
- Garcia, J., Ervin, F. R., & Koelling, R. A. (1967). Toxicity of serum from irradiated donors. *Nature*, 213, 682–683.
- Garcia, J., Kimeldorf, D. J., & Koelling, R. A. (1955). Conditioned aversion to saccharin resulting from exposure to gamma radiation. *Science*, 122, 157–158.
- Gould, J. L. (1998). Sensory bases of navigation. *Current Biology*, 8, R731–738.
- Green, L., & Rachlin, H. (1973). The effect of rotation on the learning of taste aversions. *Bulletin of the Psychonomic Society*, 1, 137–192.
- Green, L., & Rachlin, H. (1976). Learned taste aversions in rats as a function of delay, speed, and duration of rotation. *Learning and Motivation*, 7, 283–289.
- Halliday, D., & Resnick, R. (1986). *Fundamentals of physics* (2nd ed.). New York: John Wiley & Sons.
- Haroutunian, V., & Riccio, D. C. (1975). Acquisition of rotation-induced taste aversion as a function of drinking-treatment delay. *Physiological Psychology*, 3, 273–277.
- Haroutunian, V., Riccio, D. C., & Gans, D. P. (1976). Suppression of drinking following rotational stimulation as an index of motion sickness in the rat. *Physiological Psychology*, 4, 467–472.
- Hirvonen, T. P., Carey, J. P., Liang, C. J., & Minor, L. B. (2001). Superior canal dehiscence: Mechanisms of pressure sensitivity in a chinchilla model. *Archives of Otolaryngology—Head & Neck Surgery*, 127, 1331–1336.
- Hopkins, J. A., & Wehrli, F. W. (1997). Magnetic susceptibility measurement of insoluble solids by NMR: Magnetic susceptibility of bone. *Magnetic Resonance in Medicine*, 37, 494–500.
- Haupt, T. A., Cassell, J. A., Cason, A. M., Reidell, A., Golden, G. J., Riccardi, C., et al. (2007). Evidence for a cephalic site of action of high magnetic fields on the behavioral responses of rats. *Physiology & Behavior*, 92, 665–674.

- Haupt, T. A., Cassell, J. A., Riccardi, C., DenBleyker, M. D., Hood, A., & Smith, J. C. (2007). - Rats avoid high magnetic fields: Dependence on an intact vestibular system. *Physiology & Behavior*, *92*, 741–747.
- Haupt, T. A., Cassell, J. A., Riccardi, C., Kwon, B. S., & Smith, J. C. (2007). Suppression of drinking by exposure to a high-strength static magnetic field. *Physiology & Behavior*, *90*, 59–65.
- Haupt, T. A., Philopena, J. M., Joh, T. H., & Smith, G. P. (1996a). c-Fos induction in the rat nucleus of the solitary tract by intraoral quinine infusion depends on prior pairing of quinine and lithium chloride. *Physiology & Behavior*, *60*, 1535–1541.
- Haupt, T. A., Philopena, J. M., Joh, T. H., & Smith, G. P. (1996b). c-Fos induction in the rat nucleus of the solitary tract correlates with the retention and forgetting of a conditioned taste aversion. *Learning & Memory*, *3*, 25–30.
- Haupt, T. A., Philopena, J. M., Wessel, T. C., Joh, T. H., & Smith, G. P. (1994). Increased c-Fos expression in the rat nucleus of the solitary tract after conditioned taste aversion formation. *Neuroscience Letters*, *172*, 1–5.
- Haupt, T. A., Pittman, D. M., Barranco, J. M., Brooks, E. H., & Smith, J. C. (2003). Behavioral effects of high strength magnetic fields on rats. *Journal of Neuroscience*, *23*, 1498–1505.
- Haupt, T. A., Pittman, D. W., Riccardi, C., Cassell, J. A., Lockwood, D. R., Barranco, J. M., et al. (2005). Behavioral effects on rats of high strength magnetic fields generated by a resistive electromagnet. *Physiology & Behavior*, *86*, 379–389.
- Hunt, E. L., Carroll, H. W., & Kimeldorf, D. J. (1965). Humoral mediation of radiation-induced motivation in parabiont rats. *Science*, *150*, 1747–1748.
- Hutchison, S. L. (1973). Taste aversion in albino rats using centrifugal spin as an unconditioned stimulus. *Psychological Reports*, *33*, 467–470.
- Innis, N. K., Ossenkopp, K. P., Prato, F. S., & Sestini, E. (1986). Behavioral effects of exposure to nuclear magnetic resonance imaging: II. Spatial memory tests. *Magnetic Resonance Imaging*, *4*, 281–284.
- Jones, S. M., Erway, L. C., Johnson, K. R., Yu, H., & Jones, T. A. (2004). Gravity receptor function in mice with graded otoconial deficiencies. *Hearing Research*, *191*(1–2), 34–40.
- Kangarlu, A., Burgess, R. E., Zhu, H., Nakayama, T., Hamlin, R. L., Abduljalil, A. M., et al. (1999). Cognitive, cardiac, and physiological safety studies in ultra high field magnetic resonance imaging. *Magnetic Resonance Imaging*, *17*, 1407–1416.
- Kaufman, G. D. (1996). Activation of immediate-early genes by vestibular stimulation. *Annals of the New York Academy of Sciences*, *781*, 437–442.
- Kaufman, G. D. (2005). Fos expression in the vestibular brainstem: What one marker can tell us about the network. *Brain Research Reviews*, *50*, 2200–2211.
- Kaufman, G. D., Anderson, J. H., & Beitz, A. (1991). Activation of a specific vestibulo-olivary pathway by centripetal acceleration in rat. *Brain Research*, *562*, 311–317.
- Kaufman, G. D., Anderson, J. H., & Beitz, A. J. (1992). Fos-defined activity in rat brainstem following centripetal acceleration. *Journal of Neuroscience*, *12*, 4489–4500.
- Kaufman, G. D., Anderson, J. H., & Beitz, A. J. (1993). Otolith-brain stem connectivity: Evidence for differential neural activation by vestibular hair cells based on quantification of Fos expression in unilateral labyrinthectomized rats. *Journal of Neurophysiology*, *70*, 117–127.
- Kimble, G. A. (1961). Parameters of reinforcement. In G. A. Kimble (Ed.), *Hilgard and Marquis' conditioning and learning* (pp. 137–166). New York: Appleton-Century-Crofts.
- Klosterhalfen, S., Ruttgers, A., Krümmey, E., Otto, B., Stockhorst, U., Riepl, R. L., et al. (2000). Pavlovian conditioning of taste aversion using a motion sickness paradigm. *Psychomatic Medicine*, *62*, 671–677.
- Levy, C. S., Carroll, M. E., Smith, J. C., & Hofer, K. G. (1974). Antihistamines block radiation induced taste aversions. *Science*, *186*, 1044–1046.
- Lövsund, P., Öberg, P. Å., Nilsson, S. E., & Reuter, T. (1980). Magnetophosphenes: A quantitative analysis of thresholds. *Medical & Biological Engineering & Computing*, *18*, 326–334.
- Marshburn, T. H., Kaufman, G. D., Purcell, I. M., & Perachio, A. A. (1997). Saccule contribution to immediate early gene induction in the gerbil brainstem with posterior canal galvanic or hypergravity stimulation. *Brain Research*, *761*, 51–58.
- Messmer, J. M., Porter, J. H., Fatouros, P., Prasad, U., & Weisberg, M. (1987). Exposure to magnetic resonance imaging does not produce taste aversion in rats. *Physiology & Behavior*, *40*, 259–261.
- Morris, D. D., & Smith, J. C. (1964). X-ray conditioned saccharin aversion induced during the immediate postexposure period. *Radiation Research*, *21*, 513–519.
- Narasimhan, P. T., & Jacobs, R. E. (1996). Neuroanatomical micromagnetic resonance imaging. In A. W. Toga & J. C. Mazziotta (Eds.), *Brain mapping: The methods* (pp. 147–167). New York: Academic Press.

- Newlands, S. D., & Perachio, A. A. (2003). Central projections of the vestibular nerve: A review and single fiber study in the Mongolian gerbil. *Brain Research Bulletin*, *60*, 475–495.
- Nolte, C. M., Pittman, D. W., Kalevitch, B., Henderson, R., & Smith, J. C. (1998). Magnetic field conditioned taste aversion in rats. *Physiology & Behavior*, *63*, 683–688.
- Okifuji, A., & Friedman, A. G. (1992). Experimentally induced taste aversions in humans: Effects of overshadowing on acquisition. *Behaviour Research and Therapy*, *30*, 23–32.
- Ossenkopp, K. P. (1983). Area postrema lesions in rats enhance the magnitude of body rotation-induced conditioned taste aversions. *Behavioral and Neural Biology*, *38*, 82–96.
- Ossenkopp, K. P., Innis, N. K., Prato, F. S., & Sestini, E. (1986). Behavioral effects of exposure to nuclear magnetic resonance imaging: I. Open-field behavior and passive avoidance learning in rats. *Magnetic Resonance Imaging*, *4*, 275–280.
- Ossenkopp, K. P., Kavaliers, M., Prato, F. S., Teskey, G. C., Sestini, E., & Hirst, M. (1985). Exposure to nuclear magnetic resonance imaging procedure attenuates morphine-induced analgesia in mice. *Life Science*, *37*, 1507–1514.
- Ossenkopp, K. P., Parker, L. A., Limebeer, C. L., Burton, P., Fudge, M. A., & Cross-Mellor, S. K. (2003). Vestibular lesions selectively abolish body rotation-induced, but not lithium-induced, conditioned taste aversions (oral rejection responses) in rats. *Behavioral Neuroscience*, *117*, 105–112.
- Ossenkopp, K. P., Rabi, Y. J., Eckel, L. A., & Hargreaves, E. L. (1994). Reductions in body temperature and spontaneous activity in rats exposed to horizontal rotation: Abolition following chemical labyrinthectomy. *Physiology & Behavior*, *56*, 319–324.
- Ritter, S., McGlone, J. J., & Kelley, K. W. (1980). Absence of lithium-induced taste aversion after area postrema lesion. *Brain Research*, *201*, 501–506.
- Roentgen, W. C. (1895). On a new kind of rays. *Sitzgeber. Physik.-Med.Ges.Wurzburg*, 137.
- Roentgen, W. C. (1897). Further observations on the properties of the X-rays. *Math. u. Naturw. Mitt. a.d. Sitzgsber. Preuss. akad. Wiss., Physik-Math.Kl.*, 392.
- Schenck, J. F. (1992). Health and physiological effects of human exposure to whole-body four-tesla magnetic fields during MRI. *Annals of the New York Academy of Sciences*, *649*, 285–301.
- Schenck, J. F., Dumoulin, C. L., Redington, R. W., Kressel, H. Y., Elliot, R. T., & McDougall, I. L. (1992). Human exposure to 4.0-Tesla magnetic fields in a whole body scanner. *Medical Physics*, *19*, 1089–1098.
- Semenov, L. V., & Bures, J. (1989). Vestibular stimulation disrupts acquisition of place navigation in the Morris water tank task. *Behavioral and Neural Biology*, *51*, 346–363.
- Smith, J. C. (1970). Conditioned suppression as an animal psychophysical technique. In W. C. Stebbins (Ed.), *Animal psychophysics: The design and conduct of sensory experiments* (pp. 125–159). New York: Appleton-Century-Crofts.
- Smith, J. C. (1971). Radiation: Its detection and its effect on taste preferences. In E. Stellar & J. Sprague (Eds.), *Progress in physiological psychology* (Vol. 4, pp. 53–118). New York: Academic Press.
- Smith, J. C., & Blumsack, J. T. (1981). Learned taste aversion as a factor in cancer therapy. *Cancer Treatment Reports*, *65*, 37–42.
- Smith, J. C., Blumsack, J. T., & Bilek, F. S. (1985). Radiation-induced taste aversions in rats and man. In T. G. Burish, S. M. Levy, & B. E. Meyerowitz (Eds.), *Cancer, nutrition and eating behaviors: A biobehavioral perspective* (pp. 77–101). Mahwah, NJ: Lawrence Erlbaum.
- Smith, J. C., Blumsack, J. T., Bilek, F. S., Spector, A. C., Hollander, G. R., & Baker, D. L. (1984). Radiation-induced taste aversion as a factor in cancer therapy. *Cancer Treatment Reports*, *68*, 1219–1227.
- Smith, J. C., Hollander, G. R., & Spector, A. C. (1981). Taste aversions conditioned with partial body radiation exposures. *Physiology & Behavior*, *27*, 903–913.
- Smith, J. C., Morris, D. D., & Hendricks, J. (1964). Conditioned aversion to saccharin solution with high dose rates of X-rays as the unconditioned stimulus. *Radiation Research*, *22*, 507–510.
- Smith, J. C., & Roll, D. L. (1967). Trace conditioning with X-rays as an aversive stimulus. *Psychonomic Science*, *9*, 11.
- Smith, J. C., & Schaeffer, R. W. (1967). Development of water and saccharin preferences after simultaneous exposures to saccharin solution and gamma rays. *Journal of Comparative and Physiological Psychology*, *63*, 434–438.
- Smith, J. C., Taylor, H. L., Morris, D. D., & Hendricks, J. (1965). Further studies of X-ray conditioned saccharin aversion during the post exposure period. *Radiation Research*, *24*, 423–431.
- Snyder, D., Jahng, J. W., Smith, J. C., & Houpt, T. A. (2000). c-Fos induction in visceral and vestibular nuclei of the rat brainstem by a 9.4 T magnetic field. *NeuroReport*, *11*, 1681–1685.

- Spector, A. C., Smith, J. C., & Hollander, G. R. (1981). A comparison of dependent measures used to quantify radiation-induced taste aversion. *Physiology & Behavior*, *27*, 887-901.
- Spector, A. C., Smith, J. C., & Hollander, G. R. (1983). The effects of postconditioning CS experience on recovery from radiation-induced taste aversion. *Physiology & Behavior*, *30*, 647-649.
- Spector, A. C., Smith, J. C., & Hollander, G. R. (1986). Radiation-induced taste aversion: Effects of radiation exposure level and the exposure-taste interval. *Radiation Research*, *106*, 271-277.
- Sutton, R. L., Fox, R. A., & Daunton, N. G. (1988). Role of the area postrema in three putative measures of motion sickness in the rat. *Behavioral and Neural Biology*, *50*, 133-152.
- Swank, M. W., & Bernstein, I. L. (1994). c-Fos induction in response to a conditioned stimulus after single trial taste aversion learning. *Brain Research*, *636*, 202-208.
- Swank, M. W., Ellis, A. E., & Chochran, B. N. (1996). c-Fos antisense blocks acquisition and extinction of conditioned taste aversion in mice. *Neuroreport*, *7*, 1866-1870.
- Swank, M. W., Schafe, G. E., & Bernstein, I. L. (1995). c-Fos induction in response to taste stimuli previously paired with amphetamine or LiCl during taste aversion learning. *Brain Research*, *673*, 251-261.
- Taylor, H. L., Smith, J. C., Wall, A. H., & Chaddock, B. (1968). Role of the olfactory system in the detection of X-rays by the rhesus monkey. *Physiology & Behavior*, *3*, 929-933.
- Teskey, G. C., Ossenkopp, K. P., Prato, F. S., & Sestini, E. (1987). Survivability and long-term stress reactivity levels following repeated exposure to nuclear magnetic resonance imaging procedures in rats. *Physiological Chemistry and Physics and Medical NMR*, *19*, 43-49.
- Winther, F. Ø., Rasmussen, K., Tvete, O., Halvorsen, U., & Haugsdal, B. (1999). Static magnetic field and the inner ear: A functional study of hearing and vestibular function in man after exposure. *Scandinavian Audiology*, *28*, 57-59.

